

Translation of the original instructions code 35451490 Starting from serial number C300046

04/2023



MECCANICA BENASSI S.r.l.

Ride-on Flail Mower - FOX Series

User and Maintenance Manual



FOX 95-2WD

1a - MACHINE GENERAL DESCRIPTION AND PURPOSE

The ride-on flail mower *FOX 95-2WD* by *Meccanica Benassi* is a professional machine designed and built for mowing grass, shrubs, scrub, uncultivated greenery, undergrowth and young woody vegetation. It is intended for professional and trained operators, who have the necessary knowledge and expertise to understand how to operate this tractor and minimise risk and danger.

1b - USER'S MANUAL



When present, the danger symbol indicates a situation that can cause death or serious injuries to the operator or to the people exposed.



A careful read and understanding of this manual is a **MANDATORY** and **ESSENTIAL** condition to properly use the machine, in order to prevent damage, injuries or deaths. The manual must be kept carefully. Any possible operator other than the machine buyer must read and understand the manual as well. In case of sale, rental, loan, contract works etc., this manual must be always supplied with the machine. **In case of loss, ask for another copy** of the manual to your usual retailer or directly to the manufacturer. Moreover, it is recommended to download a PDF copy of the manual

from the website www.benassi.it/en, so to be able to read it also using a smartphone or in the event the hard copy has been (temporarily) lost. In the event the user does not observe the instructions contained in this manual, (s)he will be responsible for any damage to people, objects, animals or property. It is **MANDATORY** and **ESSENTIAL** to read and understand the user's manual of the engine manufacturer, supplied with the machine.

CONTENTS

- 1a – MACHINE GENERAL DESCRIPTION AND PURPOSE
- 1b – USER'S MANUAL: reading and understanding
- 1c – INTENDED USE
- 1d – UNFORESEEN, FORBIDDEN AND DANGEROUS USE
- 2a – PICTOGRAMS: map and explanation of their meaning
- 2b – CE MARKING: position and content
- 3a – GENERAL SAFETY INSTRUCTIONS
- 3b – USE RESTRICTIONS
- 3c – HAZARDS AND INSTRUCTIONS ON FUEL USE – RISKS ASSOCIATED WITH ENGINE OPERATIONS
- 4a – DESCRIPTION OF THE MACHINE MAIN PARTS
- 4b – PACKAGING, TRANSPORT, SAFE MOVEMENT
- 5 – PRELIMINARY CHECKS
- 6a – CONTROL ELEMENTS/ADJUSTMENT
- 6b – TURNING THE MACHINE ON/OFF
- 6c – MOWING
- 6d – USE OF THE MACHINE
- 7a – MAINTENANCE AND CLEANING
- 7b – FUEL, HYDROSTATIC OIL, ENGINE OIL
- 7c – CHECKS AND MAINTENANCE OPERATIONS TO BE CARRIED OUT BEFORE EACH USE
- 7d – CHECKS AND MAINTENANCE OPERATIONS TO BE CARRIED OUT AT REGULAR INTERVALS
- 7e – TROUBLESHOOTING
- 8 – STORAGE AND DISPOSAL
- 9a – TECHNICAL DATA
- 9b – ELECTRICAL SYSTEM DIAGRAM
- 10 – WARRANTY: conditions
- 11 – SERVICE SHEET
- 12 – DECLARATION OF CONFORMITY

1c – INTENDED USE

The ONLY intended use is mowing operations carried out on terrains with grass, vine shoots, uncultivated greenery, and sparse timber with trunks having a size proportional to this tool. The machine is designed to be used by a single operator riding it, who works observing ALL the instructions contained in this manual and in the manual supplied by the engine manufacturer.

1d – UNFORESEEN, FORBIDDEN AND DANGEROUS USE

It is forbidden to use the machine:

- as a toy
- as a tool for towing, pulling or pushing
- as a tool used to transport objects, people and animals
- as a generic grinder for stones, wood, debris, waste, pruning, etc.
- for mowing operations on roofs or unstable, artificial, elevated surfaces
- for transfer on public roads
- in any other condition not described in the previous paragraph 1c “*INTENDED USE*”

Any damage caused by an unforeseen, forbidden or dangerous use makes any warranty claim related to the machine, engine or hydrostatic transmission null. Refer to the list of the other Warranty Conditions in Chap. 10.

2a – PICTOGRAMS: map and explanation of their meaning

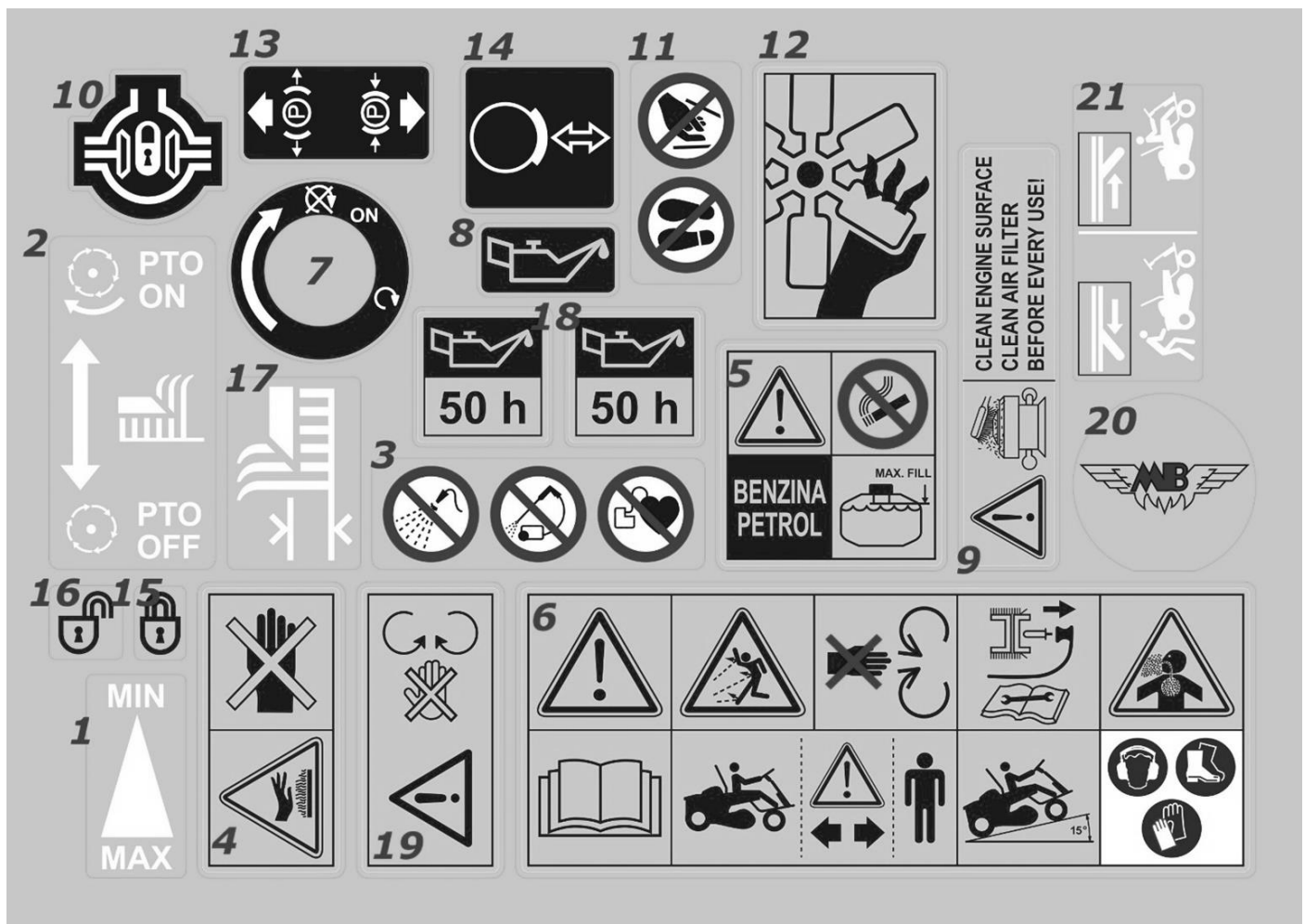

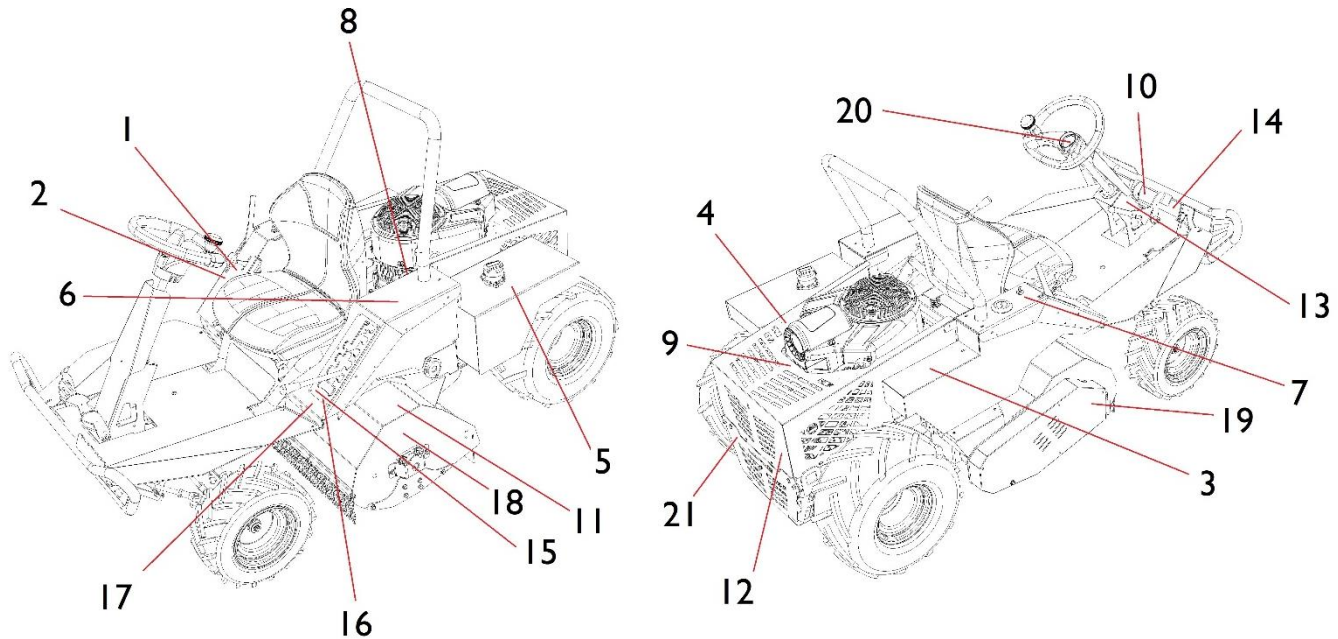

EXPLANATION OF THE PICTOGRAMS ON THE MACHINE:

- 1) Engine revolutions adjustment, from minimum to maximum. While cutting, always keep it on MAX.
- 2) Rotor engagement (*PTO ON* to operate, *PTO OFF* rotor stopped).
- 3) Prohibition of cleaning the machine using a water jet⁽¹⁾ or a high-pressure water jet cleaner. Operators with a pacemaker are not allowed to come into contact with the electrical parts.
⁽¹⁾ *with the exception of the rotor washing, for which a special hose holder is supplied, as shown in **chapter 4b***
- 4) Burn hazard due to hot metal covers in the area around engine and muffler.
- 5) Ignition hazard due to flammable fuel: do not smoke! Use lead-free petrol only and do not fill above the maximum allowed level. Fill up the tank slowly to avoid spilling the fuel.
- 6) Before operating the machine, read and understand this manual. Object projection hazard. Keep a safety distance from other people, objects and animals. Maximum allowed slope during continuous use in all directions equal to 15° (28%). Be careful not to come into contact with the rotating mechanical parts, even if they are protected. Before any maintenance operation, remove the ignition key and spark plug cap. Beware of the danger of inhaling harmful exhaust gases, even in open spaces (when the operator is downwind). The use of *Personal Protective Equipment*, such as anti-noise earmuffs, gloves and work shoes, is mandatory.
- 7) Ignition key positions and clicks: turn clockwise to turn the tractor on.
- 8) **Before each use**, check the level of the hydrostatic oil and engine oil.
- 9) **Meaning: "CLEAN THE ENGINE CONVEYOR, CLEAN AIR FILTER BEFORE EVERY USE!"**
- 10) It indicates the pedal to the left of the steering wheel: when pressed, the rear differential lock is engaged.
- 11) Stepping on the rotor casing is forbidden, do not use it as a ladder. Do not put your hands inside the casing.
- 12) Pay attention to the moving parts on the rear, especially the hydrostatic unit cooling fan.
- 13) Positions of the parking brake lever.
- 14) It indicates the pedal to the right of the steering wheel: when pressed, the machine brakes.
- 15) It indicates the FIXED cutting positions.
- 16) It indicates the FLOATING cutting positions.
- 17) It indicates the cutting height adjustment lever.

- 18) Rotor bearings greasing reminder.
- 19) Rotating parts hazard (belt drive under the protective casing).
- 20) Company logo.
- 21) Rear by-pass lever positions.

All the instructions and procedures summarised by the pictograms are explained in detail in subsequent sections of this manual.

2b – CE MARKING

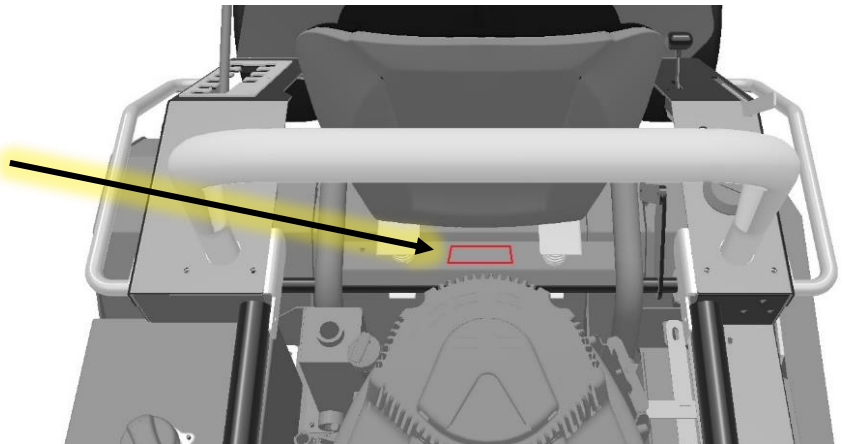

The CE plate is placed on the spring support plate, under the seat (see figure above).

Content:

- Manufacturer name and address
- Machine type
- Machine model
- Serial number
- Engine net power
- Machine dry mass
- Year of production



3a – GENERAL SAFETY INSTRUCTIONS

- **BEFORE** using the machine, IT IS ESSENTIAL to read and understand this manual and the attached engine manufacturer manual. The FOX ride-on flail mower is a professional machine: therefore, it is important to ask for clarifications also in case of apparently simple doubts. Your local retailer or the manufacturer will be available to provide the needed answers.

- Have the main control elements and the specific operations of the machine explained by the qualified personnel of the *Meccanica Benassi* sales network.
- **It is strictly forbidden** to tamper in any way with the control elements or other technical characteristics of this machine.
- **It is strictly forbidden** to intervene on or modify in any way the engine characteristics, especially its maximum RPMs (this can cause irreversible damage to the hydrostatic transmission).

- **It is strictly forbidden** to place loads on the seat or tamper in any other way with the weight sensor positioned inside the seat.
 - **With the engine on, it is strictly forbidden to do anything other than the mowing operations carried out by the operator on the driver seat.**
 - With the engine on, it is strictly forbidden to carry out any adjustment, maintenance intervention or action by a third party while the operator is on the driver seat.
 - It is strictly forbidden to load objects, people and animals in addition to the operator driving the machine.
 - It is strictly forbidden to transport, tow and push objects, people or animals.
 - **Before starting to work, it is recommended to get acquainted with the machine in a wide, clear space.**
 - It is important to understand the meaning and purpose of all labels affixed to the machine. In case of doubts on the meaning of one or more symbols, contact your usual retailer.
 - During work, the operator must always wear suitable *Personal Protective Equipment*, such as gloves, safety shoes, tight work clothes and anti-noise earmuffs.
- 
- Before each use, it is essential to check the correct functioning of the seat sensor. **If the operator gets off the seat and the engine DOES NOT TURN OFF, using the machine is forbidden and it will be necessary to contact an authorised workshop as soon as possible.**
 - Before turning the machine on or during work operations, check that there are no people or animals within the machine danger zone (15-metre radius around the machine).
 - Before turning the machine on, check that there are no objects on the ground that can be projected.
 - Before starting to work, it is recommended to check the ground where the mowing operations will be carried out: the presence of foreign bodies, in case of impact, can damage the machine. In case of debris projection, this might lead to damage to objects, people or property. The most exposed area is the left front one from the operator's point of view.
 - In case of reverse travel, always make sure that there are no people or obstacles behind the machine.
 - In case of impact between rotor and a foreign body, immediately stop the machine and check the state of the rotor and of the rest of the machine. It is necessary to immediately turn off the engine, remove the key and inspect the flail rotor. In case of serious damage, missing blades, or vibrations, stop the operation and fix the issue as soon as possible.
 - Mowing operations must always be carried out with the engine at its maximum RPMs and with a forward speed and cutting height proportional to the grass and shrubs height.
 - Every time the operator needs to get off the machine, it is advisable to disengage the cutting element, insert the parking brake, turn the engine off, and remove the ignition key.
 - If the ground is uneven or has holes (especially on slopes), decrease the speed and bring it to the minimum when changing direction. Tip-over hazard!
 - Keep away from verges and cliffs, pay attention to any danger hidden by the vegetation to be mowed, such as holes, bumps, stones, and roots.
 - NEVER disengage the drive while on slopes: the by-pass lever (pos. 11 Chap. 6a) must always be on the ON position.
 - When moving the machine or performing mowing operations, it is advisable to always proceed in the gradient direction (upstream or downstream) and not transversely to the slope.
 - Do not change the travel direction while on slopes; if needed, use the differential lock both uphill and downhill!
 - While on slopes, decrease the speed, keep it constant, avoid sudden acceleration or braking, firmly hold the steering wheel.
 - NEVER tamper with the seat sensor functioning.

- Damaged blades must be replaced, and not repaired nor sharpened. A rotor having one or more broken blades will be unbalanced and transfer unexpected vibrations to the rest of the structure and operator. Wear gloves during inspection and maintenance operations.
- If the operator experiences hand, arm or leg fatigue, stop working and take a break until sensitivity has been completely recovered. Such loss of sensitivity can also be prevented using work gloves.
- It is advisable to take more frequent breaks also in the case of body distress/fatigue, if operations are carried out on uneven grounds for a long time.
- The electrical circuit generates an electromagnetic field generally not harmful for the human body. **People with a pacemaker or similar devices must obtain the authorisation to operate the machine by their physician.**
- Movements from one work area to another must be made with the rotor placed in the highest position and with the tools not inserted.



3b – USE RESTRICTIONS

- The use of the machine is forbidden to children and, in general, to people who do not know how it works or have not read or understood this manual.
- Minors are not allowed to use the machine. To establish the minimum legal age of the operator, refer to the local regulations in force.
- The machine is not equipped with an artificial lighting system. The LEDs on the pillar are only position lights. Operations in conditions of poor natural visibility (full visibility for at least 100 meters) are forbidden.
- It is forbidden to use the machine under the influence of alcohol, drugs, medications, or in case of fatigue, illness or mental disorders.
- It is forbidden to use the machine near verges, slope sides, trenches and, in general, on unstable grounds: **tip-over hazard!**
- It is forbidden to use the machine on gravel terrains: the rotor might lift the stones, projecting them beyond the danger zone.
- It is forbidden to use the machine if the air filter is clogged, when it is missing or in case of damaged or missing muffler.
- Check the machine before each work shift: the mandatory inspections to be carried out are described later in this manual.
- It is forbidden to use the machine on public roads.
- When children are present, keep the ignition keys where they cannot reach them.
- Even with all the special covers in place, the risk of injuries to the lower or upper limbs is still present, due to the flail rotation and movement of other parts, such as the hydrostatic cooling fan and belt drive. **Never put hands or feet under the rotor casing, nor inside any other panel or protection.**
- The machine rotating parts can cut or trap hands, feet, hair, clothes or accessories. **Danger of amputation or severe lacerations!**
- Always use the machine with the protective casings in place. It is forbidden to use the machine without the protective casings in place or with PVC skirts and chains missing, broken or worn.
- Keep hands and feet away from the rotating parts.
- Tie the hair and remove jewellery.
- Do not wear loose clothes, long laces or other items that can get stuck. Always work wearing tight work clothes.
- **Do not force the engine**, especially if smoke comes out of the exhaust pipe, if its number of RPMs drops or it turns off frequently. If a specific work is not feasible, decrease the speed, raise the cutting height, carry

out the operation in separate steps. It is important to know the limits of this machine and when another equipment is necessary.

– **Do not expose the machine directly to rain:** the electrical contacts might get damaged, and grip will exponentially decrease on slopes.



3c – HAZARDS AND INSTRUCTIONS ON FUEL USE, RISKS ASSOCIATED WITH ENGINE OPERATIONS

– The fuel used for these engines (**lead-free petrol**) is toxic and flammable. Pay attention to fire and toxic vapour inhalation hazards.

– The fuel must always be handled wearing gloves, so to avoid direct contact with the skin.

– Use a funnel to fill the tank and, in case of spillage, immediately wipe dry using a cloth.

– While refuelling, use a very fine filter: the fuel must reach the engine as clean as possible.

– **Perform refuelling operations only outdoors and with the engine turned off and cold.**

– Do not spill petrol on the ground, in the environment or on the rest of the machine.

– **Do not smoke during refuelling operations or while working:** the fire risk is always present.

– **Store the fuel in closed, fresh spaces, away from sunlight, inside approved containers** and away from people or animals.

– Petrol vapours have high ignition potential: do not park the machine in closed spaces while it is still hot. **Allow the machine to cool down before parking it in a closed location.** Wait at least 15 minutes before removing the cap from the petrol tank.

– If leaks are detected, the petrol tank must be immediately replaced.

– In case of breakage or leaks, filler neck, petrol cap and supply hose must also be replaced.

– In case of excessive exposure to fuel (inhalation, ingestion, contact with the eyes), call immediately the emergency number.

– Fill the fuel tank outdoors and in a well-ventilated area.

– Do not pour an excessive amount of fuel in the tank and do not fill over the internal bottleneck. The fuel must be allowed to expand.

– Keep the fuel away from sparks, open flames, pilot lights and other ignition sources.

– **Frequently check the fuel-related utilities to detect leaks** (i.e. tank, cap and accessories). If needed, replace them.

– If fuel gets spilled, wait until it has evaporated, then wipe dry the dirty surfaces and turn the engine on only when this operation has been carried out.

When starting up the engine

– Make sure that the spark plug, silencer, fuel cap and air filter are in their place and well fixed.

– Make sure that the air filter is clean; if not, proceed as described in **CHAP. 7c**.

– Do not start the engine without spark plugs.

When using the machine

– Limit its use to maximum continuous slopes of 15°, in order to avoid fuel spillage and fumes coming out the exhaust pipe, especially when the machine is moving uphill, and the engine cylinder heads are downstream.

– Never start or operate the engine when the air filter is absent or clogged.

When the machine is tilted for maintenance

– The fuel tank must be empty; otherwise, a fuel spillage might occur, causing fire or explosion hazards.

When transporting the machine

– Transport the machine with the fuel tank filled to the minimum and top it up only after having unloaded the machine in an open, well-ventilated space.

Machine storage with fuel in the tank

– Always keep away from furnaces, stoves, water heaters or other appliances that have a pilot light or other ignition sources, as they could ignite fuel vapours.

When the engine starts up, a spark is produced. Sparks can ignite nearby flammable gases. This might cause explosion or fire.

– Do not use pressurised starting fluids, as their vapours are flammable.
– When the engine is cold, ALWAYS remove the debris building up in the silencer and engine area. **Pay special attention to the debris building up on the flywheel cover** (see Fig. on the side). Keep in mind that the debris collected on the engine, manifold, muffler and battery might catch fire! Check and cleaning operations involving this area must be carried out even more than once in the same work session, if the environmental conditions (i.e. a lot of dust) require so.

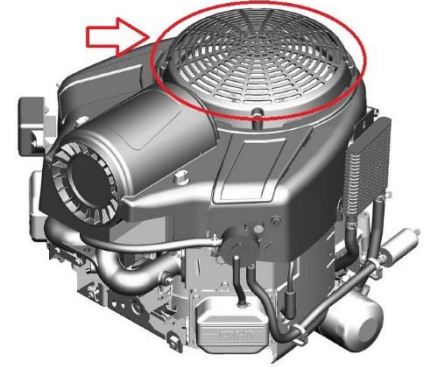

The engine exhaust contains carbon monoxide, a poisonous gas that can kill in minutes. It cannot be seen, it does not have any taste nor smell. Even if the exhaust fumes are not inhaled, it is always possible to be exposed to carbon monoxide. **If you feel sick, unwell or weak when using the machine, IMMEDIATELY stop the engine and contact a physician.** This might be due to carbon monoxide poisoning.

– Use this machine ONLY outdoors, away from windows, doors or fans, in order to reduce the risk that the carbon monoxide builds up and reaches spaces occupied by other people or animals.
– DO NOT use the machine inside the house, in garages, basements, cavity walls, sheds or other partially closed spaces, even if there are fans or the doors/windows are open. Carbon monoxide builds up fast in these spaces, and it can stagnate for several hours even after the machine has been turned off.
– Try as much as possible to use the machine upwind, so to inhale as little gas as possible.

When turned on, engines generate significant heat. **Some parts, especially the silencer and the rear metal cover (figure on the side) can become extremely hot.**

In case of contact with hands, there is the risk of serious burns. Use the machine wearing work gloves and keep away from these surfaces.

Before touching any part of the engine or its utilities, allow silencer, cylinders, cylinder heads and fins to cool down.

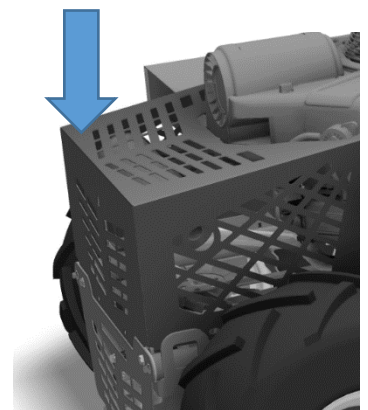

4a – DESCRIPTION OF THE MACHINE MAIN PARTS

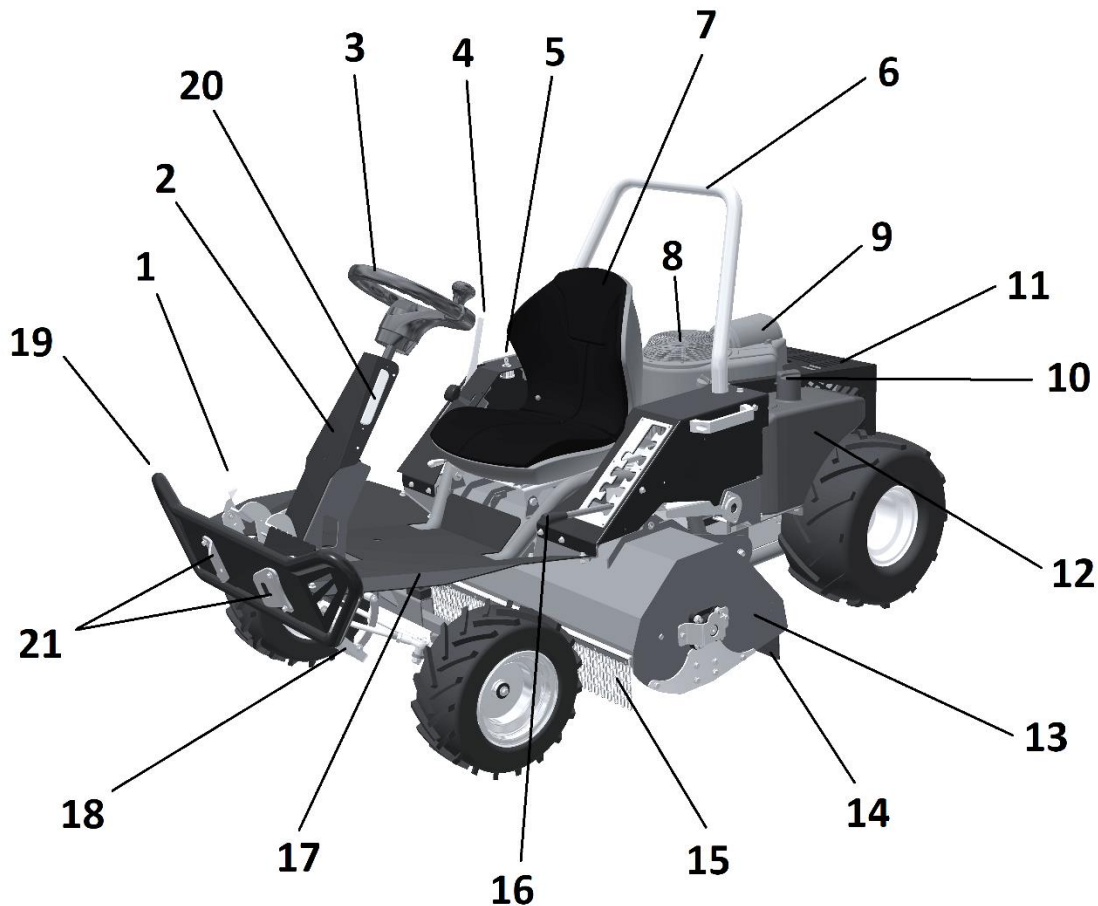

- 1) Travel direction, brake, differential lock pedals and parking brake lever.
- 2) Steering column cover panel
- 3) Steering wheel
- 4) Flail rotor engagement lever
- 5) Engine ignition key
- 6) Fixed protection bar (not an approved ROPS)
- 7) Seat
- 8) Engine
- 9) Engine air filter
- 10) Petrol tank cap
- 11) Engine hood
- 12) Petrol tank
- 13) Flail rotor protective casing – **DO NOT USE TO STEP ON THE MACHINE!**
- 14) Rear protective skirts
- 15) Protection chains
- 16) Cutting height adjustment lever
- 17) Floor: **step on the machine from here** while holding the steering wheel with one hand, and the seat with the other
- 18) Front protection
- 19) Front bumper
- 20) LED position lights (not working lights)
- 21) Front tow hooks



4b – PACKAGING, TRANSPORT, SAFE MOVEMENT

Depending on the case, the *FOX* tractor is delivered in two types of packaging: on pallet in a stiff carton box, or on pallet in a wooden cage.

The machine is supplied with:

- this machine manual, containing the EC Declaration of Conformity on its last page;
- *Briggs & Stratton* engine manual;
- ignition key;
- sleeve for rotor washing (screwed into the side of the deck and ready for a rubber hose).

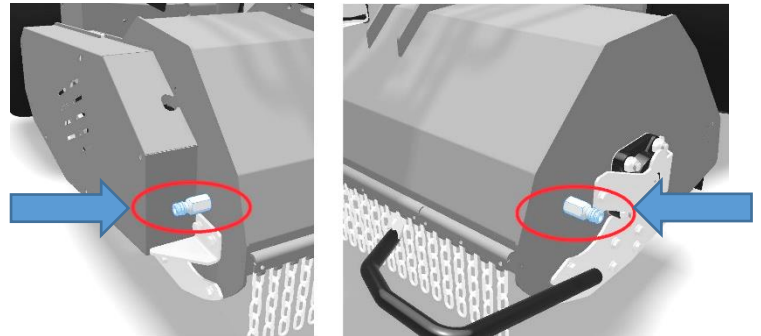

! IMPORTANT !

Check the integrity of the packaging when the machine is delivered!

If the packaging was damaged during transport, report it IMMEDIATELY, accept the delivery with reserve and document everything taking pictures. **The manufacturer is not responsible for damages occurred during transport.**

The machine is delivered ready to be used but without the petrol tank full; therefore:

- with the engine oil at the correct level. Check it anyway, see *CHAP. 7b*;
- with a minimum amount of petrol, to be used to move the machine outside the packaging. Fill up as soon as possible, see *CHAP. 7b*;
- with the hydrostatic transmission (and external tank) already filled with oil. Check anyway the level in the tank using the cap, as described in *CHAP 7b*;
- with battery charged but to be connected (first the positive + pole, then the negative -);
- with tires at the ideal pressure (in any case, perform a check as described in *CHAP. 5*).

The machine can be moved both when it is on and off, more specifically:

- **WHEN THE ENGINE IS OFF**, it is possible to:
 - push the machine, on a flat terrain (for few metres), unlocking the rear hydrostatic transmission as described in paragraph 11 - *By-pass lever* of *CHAP. 6*.
 - in case of engine failure, move the tractor using a winch suitable for towing this machine (i.e. approved for masses equal to at least 400 kg). Attach the winch to the hook welded on the front bumper, as shown in Fig. below.





IT IS FORBIDDEN TO TOW THE MACHINE FOR LONG STRETCHES AND ON PUBLIC ROADS

- **WHEN THE ENGINE IS ON**, it is possible to move the machine using its drive, **provided that all the regulations and instructions mentioned in this manual are observed.**

In the event the machine is loaded on vans or small trucks using ramps, the procedure is the following:

- Use loading ramps able to support at least 250 kg each, with non-slip surfaces and broad enough to support the tyres.
- Keep the rotor in the highest position during the loading/unloading operations.
- On the vehicle used for transport, fix the machine using belts and the anchor points shown in the figure below; then, activate the parking brake as explained in *CHAP. 6d* "Parking brake".

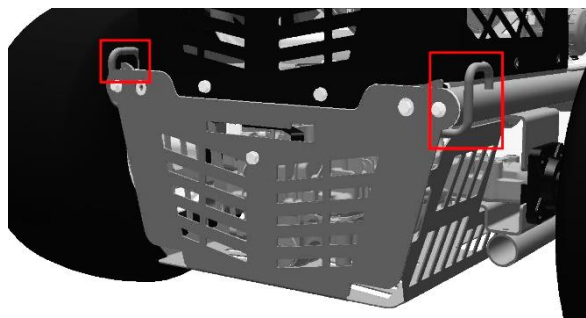

Anchor points for ropes or bands used to "block" the machine on vans or small trucks



5 – PRELIMINARY CHECKS

After having removed the machine from its packaging, **before turning it on**, read this manual IN ITS ENTIRETY and perform the **following checks**:

- **Seat adjustment check**: check that the longitudinal adjustment works properly.
- Check that there is no debris **above and around the engine**.
- Check that there is no debris **above and around the hydrostatic transmission**, and that the rear transmission cooling fan is free to rotate. If it is damaged, replace it. **DO NOT OPERATE THE MACHINE IF THE FAN IS DAMAGED!**
- **Rotor visual check**: are there blades that need to be replaced? Are the fixing screws correctly tightened? Is it free to rotate? See *Chap. 7c 4)* for further explanations.
- **Protection visual check**: Make sure that all front chains and rotor casing protective skirts are present and intact. **If some of them are broken, replace them immediately.**
- **Tyre pressure check**: the suggested value is **1.5 bar**. Check also the tyre tread wear state: worn tyres lead to traction loss and are more likely to get punctured.
- Before each use, check that all the **screws and Seeger rings fixing the wheels** are well tightened.
- **Check the battery voltage**: it must be higher than 12 V. The battery is charged and sealed. No acid is needed, and it must be charged only when necessary. If the battery struggles to get charged, get a new one, which must be original and having the same characteristics.
- **Check the functioning of all manual control elements** (see chapter 6a below), more specifically:
 - Parking brake: when the brake is engaged, are the rear wheels blocked even when the machine is pushed? If not, contact a workshop for adjustment.

- Travel direction pedal: when disengaged, it must be in neutral position. If finding the neutral position is difficult (which is an essential requirement to start the engine up), contact an authorised workshop.
 - Rotor braking: when the rotor is disengaged, the flail rotor must stop completely within 7 seconds. If this does not happen, contact an authorised workshop to adjust the brake.
 - **Check on safety systems for start-up consent:**
 - If the operator is not correctly seated, the engine must not start. Conversely, when the engine is on, check that getting off the seat causes the machine to turn off.
 - If the rotor engagement lever [#6 in Chap. 6a] is in "PTO ON" position, the engine must not start.
 - If the travel direction pedal [#1 in Chap. 6a] is in forward or reverse position, the engine must not start.
 - **Leak check** on parts such as: petrol tank, hydraulic oil tank and their hoses; engine block, carburetor, hydraulic system. If leaks are detected, do not start the machine and contact the service centre.
 - **Banding check**, more specifically: on oil hoses, petrol hose, manifold and muffler. If any component is loose, fasten everything before turning the machine on.
- IT IS PARTICULARLY IMPORTANT to check the presence of leaks on the hydraulic system: the oil can reach a peak pressure up to 500 bar!
- **Check the following levels:**
 - Engine oil at the right level, clean air filter, flywheel cover free from debris
 - Tank with enough petrol inside
 - Oil for hydrostatic transmission at the right level in its tankSee details in Chap. 7 "Maintenance".
 - Visual check of electrical fuses: replace if broken.

Before each use, check that all safety warnings are present on the machine. It is forbidden to use it before restoring missing or unreadable pictograms and markings.

If something is missing, broken, out of its place or faulty ► immediately contact your retailer and DO NOT USE the machine for any reason.

6a – CONTROL ELEMENTS/ADJUSTMENT

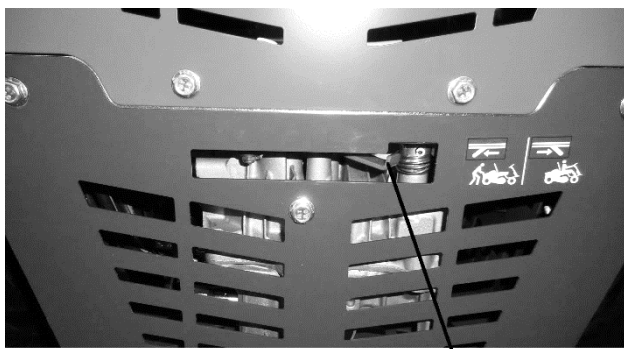
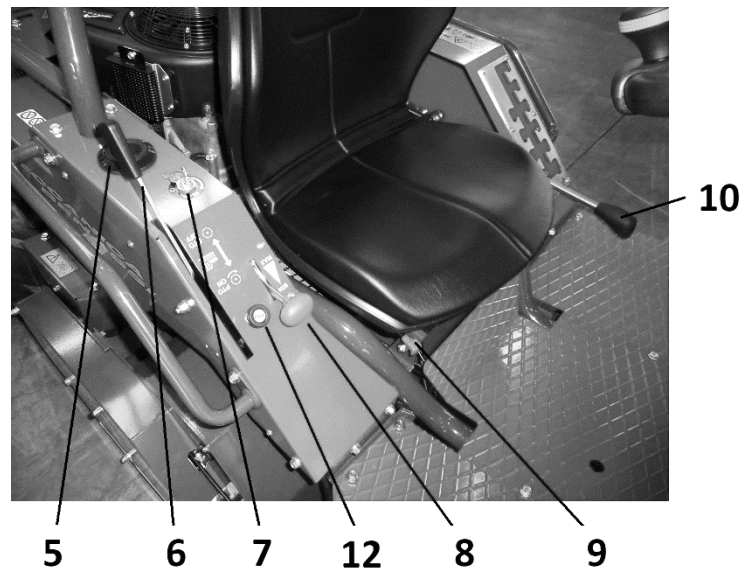
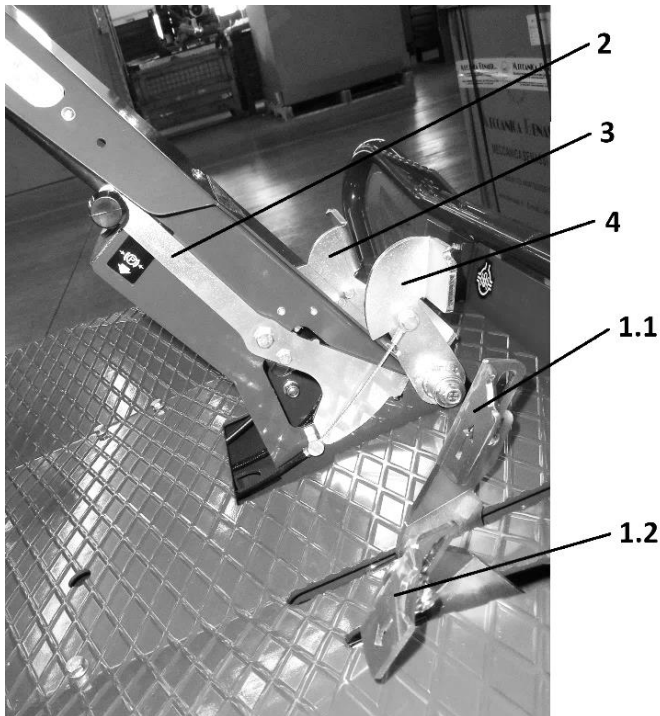

11

1.1 and 1.2– Travel direction pedal (double)

The direction of travel is set by a pair of pedals connected to each other: one for forward movement and one for reverse movement. Press the left pedal [1.1] forward to advance. Press the right pedal forward [1.2] for reverse. Both automatically return to NEUTRAL by lifting the foot, allowing the machine to slow down until it stops. To start the engine, leave both pedals free: the transmission must be neutral.

2– Parking brake lever

It keeps physically engaged the pedal brake [#4] even with the machine off.

3– Pedal for rear differential lock

Keep it COMPLETELY pressed when one of the rear wheels lose traction: use only on straight paths or on slopes in the gradient direction. Release the pedal to steer.

4– Brake pedal

The machine decreases its speed until it stops every time the right foot is raised from the travel direction pedal [#1]. If this first braking is not enough, it will be necessary to press, ALWAYS WITH THE RIGHT FOOT, the brake pedal [#4]. IT IS FORBIDDEN to use pedal #1 and pedal #4 at the same time: this might damage the rear hydrostatic transmission.

5– Analog hour counter

This tool shows the total running hours from the first start-up. It works only if the engine is on; therefore, the battery will not lose its charge when the machine is not used. This tool cannot be reset, it has no alarms nor indicator lights: periodically check the total hours to observe the maintenance intervals! ***The total hour number must always be communicated to the sales network for any warranty claim.***

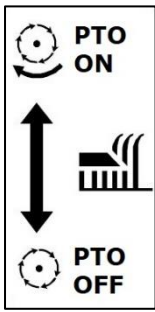

6-Rotor engagement lever

With the lever in its highest position, the flail rotor is disengaged (PTO OFF). This is an essential condition to start the engine. Then, when the engine is on and at its maximum RPMs, simply move the lever completely down to engage the rotor (PTO ON) and start the mowing operations.

While working, be careful: the highest protruding branches might press the lever, keeping it in ON position or moving it to OFF.

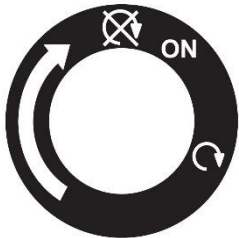

7- Key block

Turn the key to the ON position, wait for 2 seconds, then to START, until the engine starts. If the engine does not turn on, do not force it: check whether all electrical requirements for the start-up consent are met (which are explained in the next chapter). To turn the engine off, go back to the OFF position.

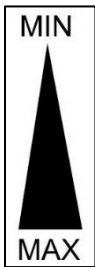

8- Throttle

The engine of this tractor goes from a minimum of 1,500 rpm (control element in MIN position) approximately up to a maximum of 3,400 rpm (control element in MAX position) approximately. During start-up operations, bring the throttle halfway. During mowing operations, ALWAYS keep the engine at its maximum RPMs. Before turning the machine off, bring the engine back to its minimum RPMs for few moments.

9 - Seat longitudinal adjustment lever

To move the seat forward or backward and adjust it to the operator's height, the lever [#9] shown in the figure is used. Move it outwards (i.e. right from the operator position), move forward or backward together with the seat, release the lever, make a last movement until the seat can be heard clicking into its new position. Note: the seat adjustment must be carried out while the machine is off and before starting to work: NEVER attempt to adjust the seat when the machine is on or, even worse, while it is on a slope.

10 - Cutting height adjustment lever: floating and fixed positions

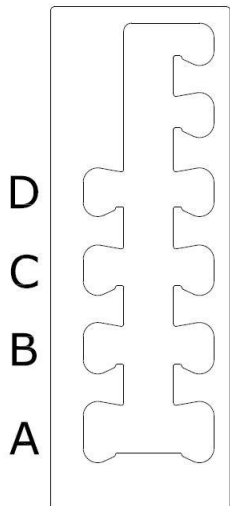

6 Lever [#10] allows to adjust the cutting height and adapt to the terrain conditions.

5 To raise the cutting height: pull the lever upwards along the grid central rail (see drawing on the side) and place it sideways in the desired position among the floating (1 to 6) or fixed ones (A to D).

4 To lower the cutting height: move the lever back to the centre of the grid, lower it and fix it in the new desired position, choosing among the floating (1 to 6) or fixed ones (A to D).

3 The lowest positions (A and 1) correspond to a cut of approximately 3 cm.

2 Position 6 corresponds to a cut of approximately 9 cm.

1 **Floating positions** of the mowing deck means those that can be selected from 1 to 6 and placed on the left side of the selection grid (from the operator's point of view). In these positions, if the deck encounters a small bump, it can rise a few centimetres following the terrain, and then returns to the selected height once it has passed the bump.

Fixed positions (A to D) are located on the right side of the selection grid (from the operator's point of view), and they "force" the mowing deck to maintain the selected height even in the presence of obstacles or vegetation pushing from the bottom upwards.

Purpose:

Floating positions from 1 to 6 are used to cut a mainly grassy terrain without obstacles or trunks: this way, the cutting result will have uniform height even in the presence of small depressions, bumps and descents. **Fixed positions from A to D** are useful in case of more demanding conditions, when the raw terrain to be shredded has resistant trunks, small trunks, shrubs to be bent with force before being shredded, etc. In these positions, the mowing deck remains in its position, and it is not "pushed back" by the obstacles, allowing to shred them in the best way.



ALL TRANSFERS MUST BE MADE WITH THE LEVER IN POSITION 6 AND WITH THE TOOLS NOT INSERTED

11 – Rear transmission by-pass lever

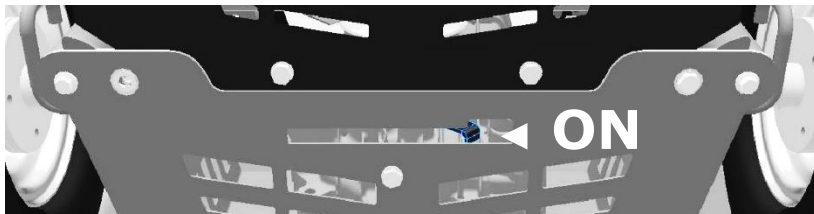

Lever [#11] has the purpose of bypassing the rear transmission, as to allow machine movement with the engine off.

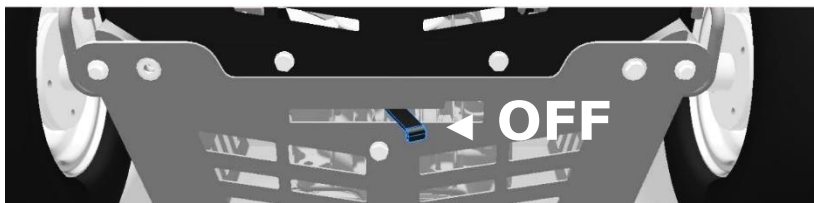

This lever has two positions:

- Lever [#11] all forward, "ON" in the previous figure: DRIVE is ENGAGED, the machine can operate
- Lever [#11] all backward (coming off the rear part), "OFF" in the previous figure: the rear transmission is free, and the machine can be moved with its engine off. **Note:** never use the OFF position while the machine is on a slope!

IMPORTANT: BRING always the lever BACK to ON position before starting a new work: otherwise, the machine will not move, and the hydrostatic transmission might get damaged!



Finally, **BEWARE** in case the machine is moved by pushing it: do not touch the rear grid while the machine is still hot, burn hazard!

12 – Mushroom control for manual air shut-off (FOX 95-4WD only)

For cold starts, control #12 must be pulled upward to close the air: when the engine is warm, bring the control back down to restore proper operation before starting work.

6b – TURNING THE MACHINE ON/OFF

During start-up operations, it is necessary to take in consideration the risk of injuring people or animals possibly within the machine operation area.

- Machine start-up must be carried out outdoors, in a well-ventilated space. In closed environments, the operator is subject to the danger of inhaling exhaust gases.
- The FOX series engines are equipped with electronic air management devices: therefore, they are not equipped with the usual choke lever used to cold start the engine.
- The machine is equipped with safety devices used for start-up consent and automatic shutdown in certain conditions. More specifically:



THE ENGINE MUST START ONLY IF:

- The operator is correctly seated (weight sensor activated by the operator weight).
- The rotor is completely disengaged (lever #6 in chapter 6a in *PTO OFF* position).
- The travel direction pedal (#1 in chapter 6a) is disengaged, i.e. automatically in neutral position.
- The parking brake lever (#2 in chapter 6a) is disengaged.
- 15 A fuse intact: it is located, together with the 20 A fuse, in the area to the operator's right, inside the control elements metal panel. See the area shown in the figure on the side.

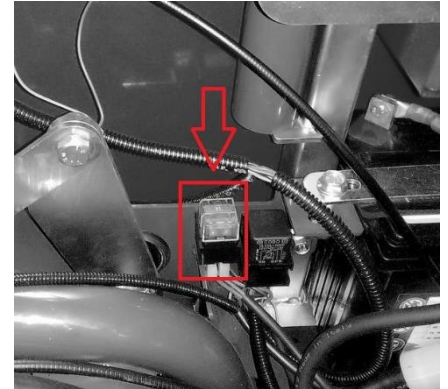

It is forbidden to use the machine if the engine starts in conditions other than those described and until all the necessary conditions are restored!

START-UP PROCEDURE: close air by pulling up on the choke control; move the throttle to MAX position; turn the key to START and release it when the engine is running. When the engine is warm bring the choke control back down for smooth operation.

SHUTDOWN: Before turning the machine off, disengage the cutting tools, move the machine drive to neutral position and move the key to the OFF position. Engage the parking brake before getting off.



NEVER LEAVE THE MACHINE UNATTENDED WITH THE KEY INSERTED!



DON'T FORGET THE KEY ON "ON": THE LIGHTS WILL EXHAUST THE BATTERY!

6c – MOWING

Preliminary instructions:

- While transferring the machine to the work area, keep the rotor in its highest position with the tools disengaged and maintain a speed suitable to the terrain conditions.
- Start working when the engine is hot; during cutting operations, use it always at its maximum RPM number.

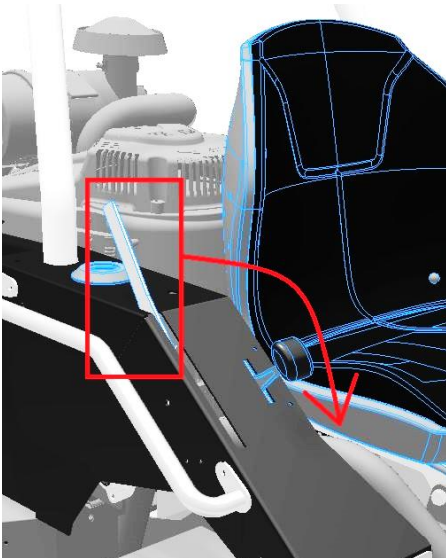

ROTOR ENGAGEMENT:

It is advisable to engage the cutting element with the engine hot and at its maximum RPMs, with the travel direction pedal in neutral position and with the rotor free to rotate. The cutting element must be engaged BEFORE entering the work area, and not in the middle of the vegetation. To engage the cutting element, COMPLETELY lower lever #6 (chap. 6a), shown in the figure on the side.

ROTOR DISENGAGEMENT:

To disengage the rotor, move lever #6 (chap. 6a) shown in the figure on the side back to the vertical position.



Note: the rotor is equipped with a brake: the flail rotor must completely stop within 7 seconds from its disengagement. If not, contact a service centre for the required inspection and adjustment.

INSTRUCTIONS FOR A CORRECT AND SAFE CUT:

The flail rotation is made possible by a belt drive. Avoid as much as possible the continuous rotor engagement/disengagement and putting the lever in intermediate positions. The rotor must be completely engaged or completely disengaged at any moment.

Before each use, check the rotor conditions. **It is essential to perform all cutting operations with all blades intact and well sharpened.** To understand if one or more blades need to be replaced, refer to *paragraph 5*. Grease the rotor support bearings as described in *Chap 7d*. In case of unusual vibrations, it is FORBIDDEN to use the machine. Check the rotor and/or contact a specialised workshop. An unbalanced rotor generates vibrations which are harmful both for the operator and the machine.

The cutting height must consider the work surface: if bumps or holes are present, adjust the height so to avoid that the blades reach the bottom of the terrain.

In all cases where cutting operations are not foreseen (e.g. transfers), the rotor **must be kept** in its highest position to avoid the risk of impact with the ground or foreign bodies.

6d – USE OF THE MACHINE

Safety warnings:

- It is always necessary that the operator stays focused in any travel or work condition. Even during simple transfers, there is always the risk of injuring people or animals, or damaging objects/property.
- Pay attention to obstacles while moving forward, and especially when moving in reverse or steering.
- It is forbidden to drive while standing, or to transport people, objects or animals.
- Pay attention to direction changes: in case of any problem, it is advisable to deactivate all control elements and stop.

– Use on slopes: the most dangerous situations require even greater attention if the machine is on steep slopes. It is advisable to remember that, when on slopes, the machine must ALWAYS move in the direction of the gradient and never transversely. The most critical stage in terms of tip-over hazard is the direction change and steering movement while on a slope. Pay the utmost attention! For further information on the use on slopes, see *Chap 3*.

– **TRAVEL DIRECTION:** pedal [#1 in *chapter 6a*] has the task of controlling the direction and speed of movement and consists of two separate appendages depending on the direction in which you want to proceed. Press the left one forward to go from standstill to the maximum speed (as indicated by the engraved arrow). Press the right pedal forward to go in reverse (as indicated by the engraved arrow). In both cases lift your foot to decrease the speed and then stop the machine when the pedal reaches its rest position (i.e. neutral position). If the pedal does not automatically return to the neutral position (when the foot is raised), see the recommendations in *CHAP. 7e – TROUBLESHOOTING*.



Pay the utmost attention especially when operating in reverse, also due to the limited view compared to the forward operations. Contain the speed, check beforehand the presence of possible obstacles behind the machine, act slowly both on pedal and steering wheel.

– **BRAKE:** as shown in *chapter 6a*, the brake pedal [#4] is the one installed on the steering column right side (from the operator position). If the automatic return to neutral position of the travel direction pedal (#1 in *chap. 6a*) is not enough to stop the machine in the required time and space, it is advisable to use the brake pedal. Press it until the end to have a strong brake, but **ONLY** after having released, with the same foot (the right one), the travel direction pedal.

The simultaneous use of brake [#4] and pedal [#1] is **DETRIMENTAL** to the internal components of the hydrostatic transmission. Any warranty claim deriving from such an incorrect use will be rejected.

– **PARKING/SERVICE:** as explained in chapter 6a on control elements, the machine is equipped with a mechanical lock [lever #2] of the brake pedal [#4], which therefore makes it a parking/service brake. Before parking and leaving the vehicle:

- Disengage the rotor.
- **Progressively** raise the right foot from the travel direction pedal until it automatically returns to the NEUTRAL position.
- Bring the throttle to the minimum.
- Activate (again using the right foot) the pedal brake by pressing it forward.
- Activate lever #2 by hand until it is locked in position (as shown in the figure on the side) with the brake pedal still pressed.
- Raise the foot from the brake pedal.
- Turn the machine off turning the key to OFF.

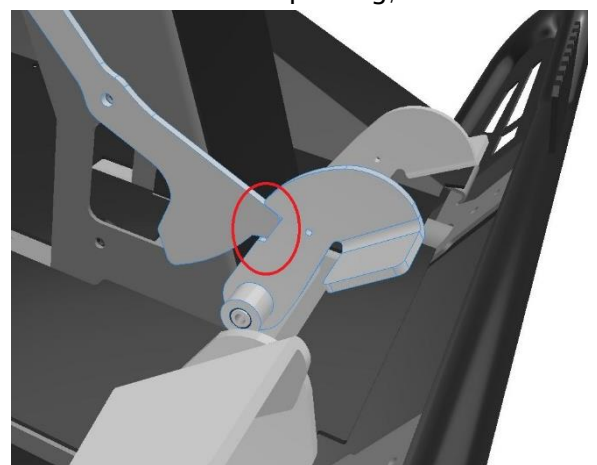

Only at this point it is possible to get off and leave the vehicle.

To RESTART from parking:

repeat the steps described above in reverse order; more importantly, before acting on the travel direction pedal, it is ESSENTIAL to unlock the parking brake! To do this, gently press the brake pedal forward => lever #2 comes out its locking position and can return to its rest position => release the brake and, with the same foot (i.e. right foot), choose the travel direction.

NEVER ACTIVATE THE TRAVEL DIRECTION PEDAL WHILE THE PARKING BRAKE IS ENGAGED: this can cause irreversible damage to the rear hydrostatic transmission!

7a – MAINTENANCE AND CLEANING



It is useful to remember, as it has been done several times in this manual, that an incorrect maintenance or performed by unauthorised workshops can expose the user to serious injury risks or technical faults not covered by the warranty.

Safety warnings:

All maintenance operations must be carried out with engine off, ignition key disengaged, parking brake engaged, and machine parked on a surface able to support it properly.

- Moreover, check if there are people nearby.
- Make sure that the machine cannot drift for any reason.
- Keep always in mind the risks connected to the use of fuel (fire and vapour inhalation) and pay attention to the presence of sharp tools.
- In the event the machine must be tilted on one side or lifted, attach the bands directly to the frame or to the front bumper hose. **NEVER LIFT the machine from its protection bar and NEVER LIFT using the anchor points for transport** (shown in *Chap. 4b*).
- During most maintenance operations, keep the engine off and remove the ignition key. The only operation for which the engine must be on is the rotor washing, which is carried out using the sleeves supplied (explanation of the procedure in *Chap. 7c 3*).
- Allow the machine to cool down before acting on any of its parts. Engine, transmissions and rear metal covers tend to retain heat for several minutes after the machine has been turned off. Therefore, it is necessary to pay attention.
- It is essential to carry out the correct disposal of petrol, oil and other special waste (such as the battery), observing the regulations in force in the territories where the machine is used and maintained. Do not dispose of them in the environment and do not treat them as regular waste.

7b – FUEL, HYDROSTATIC OIL, ENGINE OIL

FUEL

The tractor is supplied with the fuel needed for its unpacking and first start-up. **To use the machine, it is necessary to fill the petrol tank.** The tank can contain up to 13.2 litres approximately. Note: the machine is not equipped with a reserve tap nor with indicator lights for fuel level. Keep this in mind and act accordingly.

► The only type of allowed fuel is the one having the characteristics described below. Any other type of fuel might damage the engine and makes any engine-related warranty claim immediately void. Fuel must be kept in fresh, dry places, away from light and ignition sources, in approved containers suitable for this purpose.

Petrol tank cap

The petrol tank is located on the left (from the operator position); the cap (shown on the side) is unscrewed by hand, without a key. Use a funnel to make refills easier; immediately wipe dry any spills and observe all the fuel-related instructions contained in this manual (*Chap. 3c* and *7b*) and in the engine manufacturer manual.

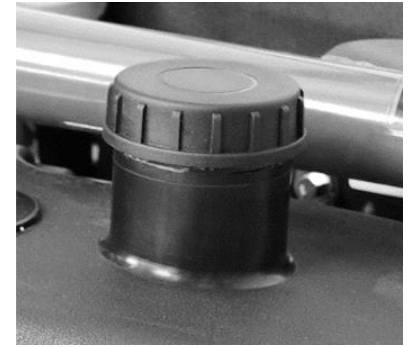

As shown in the engine manufacturer manual, **the petrol must be compliant with the following requirements:**

- These engines are certified to work with clean, new, lead-free petrol.
- Minimum 87 octanes/87 AKI (91 RON).
- Petrol having an ethanol (petrol-alcohol mixture) content up to 10% is allowed.

Note: Do not use unapproved petrol types, such as E15 or E85. Do not add oil to the petrol and do not modify the engine so it can work with alternative fuel types. The use of unapproved fuel types leads to damage not covered by the warranty.

At altitudes above 1,500 metres, petrol with a minimum octane number of 85/85 AKI (89 RON) is allowed. For information on adjustments at high altitudes, contact a *Briggs & Stratton* authorised retailer.

PETROL TANK REFILLING:

The tank can be accessed through the cap shown in the previous paragraphs. Use a funnel and, if possible, a fine filter, so to prevent impurities from getting in the tank. Every time fuel is used, follow also all the instructions contained in *Chap. 3c*.

HYDROSTATIC OIL

The *FOX 2WD* tractor relies on a hydrostatic transmission for movement. The machine is equipped with transmission, hose and external tank (see figure on the side) already filled with the right amount of oil. It is advisable to check the level inside the tank anyway before each use and, in general, to inspect the zones under the machine to check for possible leaks.

The oil tank (see Fig. on the side) is located behind the operator seat, on the left side from the driving position. It's sealed by a black plastic cap that can be unscrewed by hand.

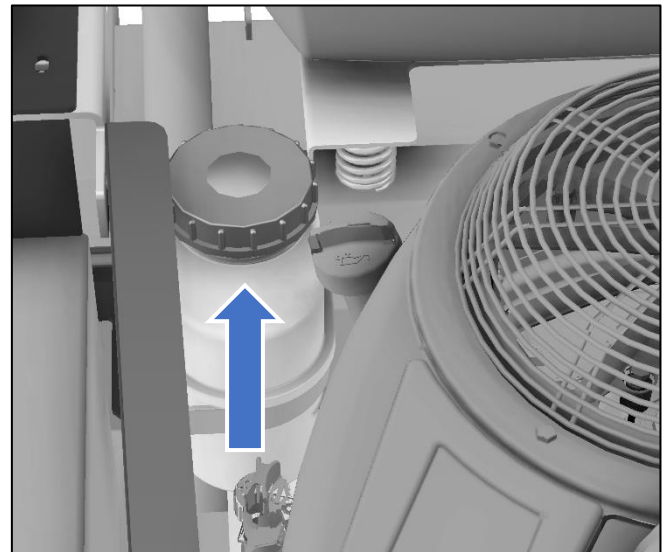

The hydrostatic transmission, hose and oil tank are factory-equipped with:

multi-purpose hydraulic oil (UTTO) ENI MULTITECH JD/F 10W-30

The use of any other type of oil on these utilities is forbidden; otherwise, the manufacturer's warranty on the hydrostatic transmission will become void (*Tuff-Torq*).

The transmission, hose and external tank contain in total more than 2 litres of oil; however, for simple and periodical top-ups, a few decilitres are enough.

HYDROSTATIC OIL LEVEL CHECK: with the machine in horizontal position and cold oil (i.e. BEFORE a work session) check that the level is around the mark engraved in the tank.

PLEASE NOTE: always leave some room to allow the hot oil to expand. Never fill the tank completely.

If the level is low, fill up according to the need, with the same type of oil used for the first fill.

For complete oil replacement operations and subsequent discharge, it is advisable to contact a specialised service centre.

ENGINE OIL

Further information is available in the engine manufacturer manual (*Briggs and Stratton*), supplied together with this machine manual. It is essential to read and understand such document in its entirety as well. **In fact, the engine warranty is covered by the engine manufacturer through its service centres located on the territory.** Below is a summary of the main information.

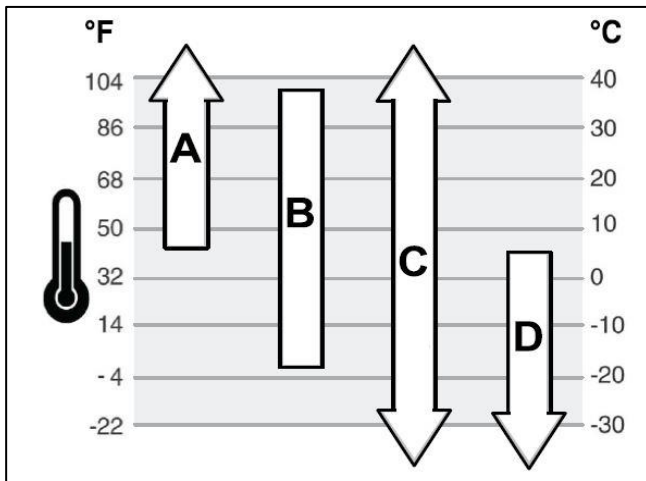

ENGINE OIL TYPE: The correct engine oil viscosity is determined by the external temperature. Use the references below to choose the most suitable type of oil according to the work temperature.

A ▶ SAE 30: Below 4°C (40°F), using SAE 30 will cause a difficult start-up.

B ▶ 10W-30: Above 27°C (80°F), using 10W-30 can cause higher oil consumption. Check the oil level more frequently.

C ▶ 5W-30 *synthetic*: covers all fields of application

D ▶ 5W-30: winter use only

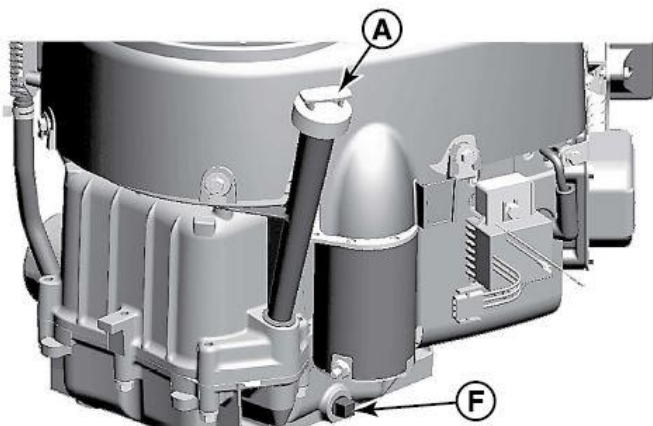

Before topping up or checking the engine oil level:

- Make sure that the machine is on a flat surface.
- Remove all debris from the oil filling area. Carry out the following operations only with the engine off and cold, with its ignition key removed.

Check and possible top-up:

- 1) Remove the level dipstick A (see figure on the side) and clean it with a cloth.
- 2) Install and tighten the dipstick again.

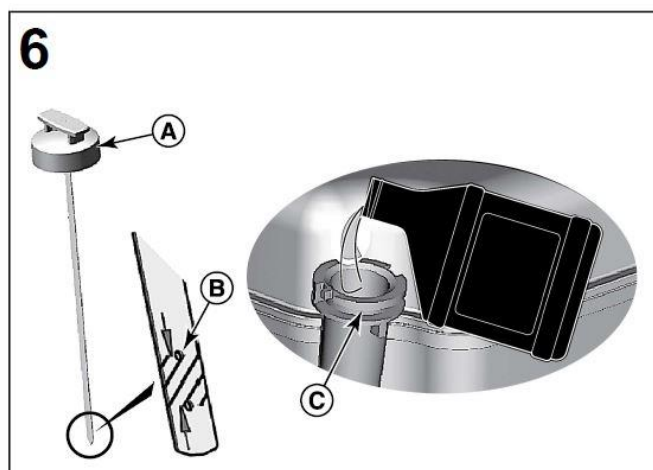

- 3) Extract the dipstick and check the oil level. The correct level corresponds to the upper mark indicated on the dipstick (B, see figure 6).
- 4) If the oil level is low, fill up slowly through the filling hole C in figure 6. Do not add too much oil. After having added the oil, wait for one minute before checking the level once again.
- 5) Reinstall and tighten the level dipstick A.

**7c – CHECKS AND MAINTENANCE OPERATIONS TO BE CARRIED OUT
BEFORE EACH USE**

1) AIR FILTER CLEANING

The air filter cleaning is essential for these machines, and it is **an operation which must be carried out before each use**.

The filter must be REPLACED with a new one **every 250 hours**. The procedure for cleaning the filter suggested by *Briggs & Stratton* is described below. Read the engine manual anyway, so to have more detailed information.

12

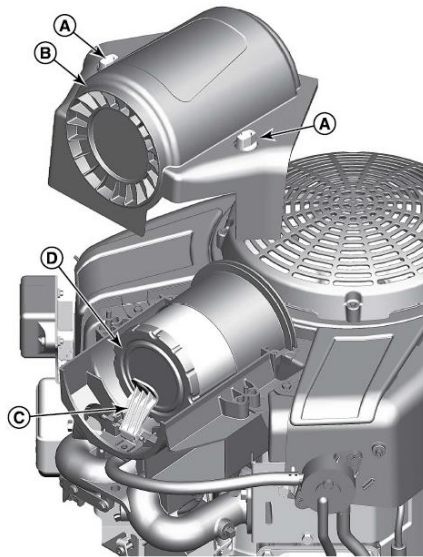

13

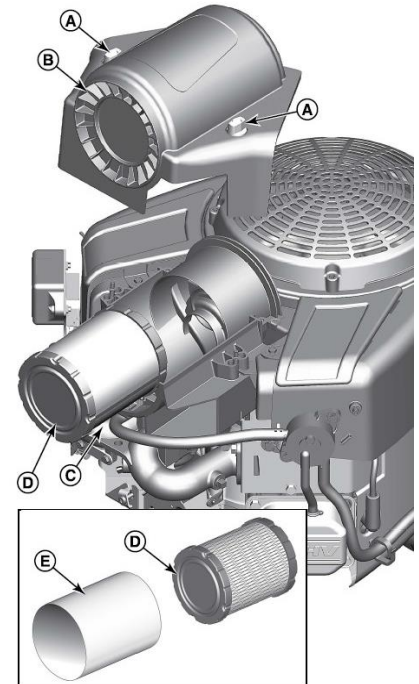

Air filter for B&S 7220

Figure 12 and 13

1. Loosen the fixing devices (A, figure 12) and remove the lid (B).
2. Open the locking device (C, figure 13) and remove the filter (D).
3. Remove the pre-filter (E, figure 13) from the filter (D), if present.
4. To remove the debris, gently tap the filter on a hard surface. If the filter is too dirty, replace it with a new one.
5. Wash the pre-filter using liquid detergent and water. Let the air dry it completely. Do not oil the pre-filter.
6. Install the dry pre-filter (E, figure 13) on the filter (D).
7. Install the filter (D, figure 12) and close the locking device (C).
8. Install the lid (B, figure 12) and tighten the fixing devices (A, figure 12).

2) CHECK OF ALL CONTROL ELEMENTS, LEVERS AND PEDALS FUNCTIONING. Visual check first, then manual check with the machine off. Check that everything is fixed correctly, without unusual clearance, clean, greased and ready to be used for work operations. All control elements are explained in *Chap. 6a*. Check the functioning of the control elements also with the engine on, in a test area, before transferring the machine and starting to work.

3) ROTOR WASHING using the supplied hose holder: screw it in the seats on the deck sides, fix the water hose and fasten it with a band. Open the jet, step on the machine and, while starting the engine, engage the rotor so it can be properly washed while turning. Note: pay the utmost attention: object projection and exhaust gas inhalation hazard. These operations must be performed outdoors, making sure to keep the deck in its lowest position.

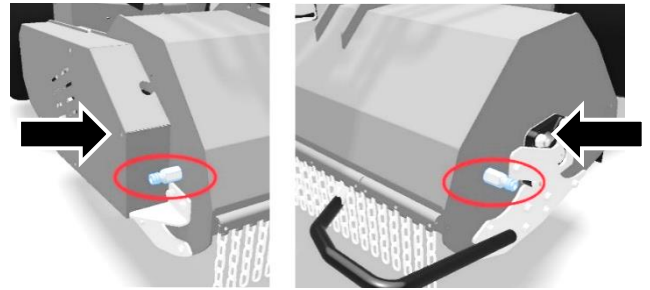

Repeat the operation on the opposite side. **Remember to remove the sleeve before starting to work!!!**

4) INSPECTION OF ROTOR BLADES and their possible replacement (use work gloves!). Keep in mind that:

- A single blade must be replaced with a new one when it is broken, bent or worn.
- All blades must be replaced (with their fixing bolts) every 50 hours as specified in Chap. 7d.

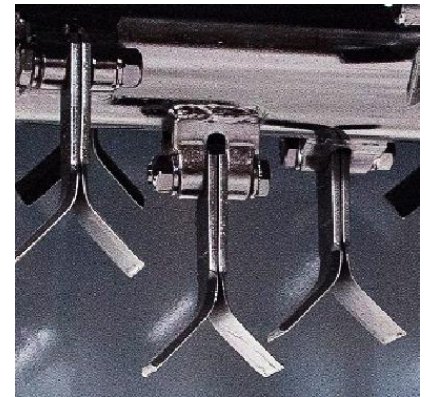

IN CASE OF ABNORMAL VIBRATIONS, COMPLETELY REPLACE ALL THE BLADES AND RELATED BOLTS

5) PETROL TANK: Does it contain the right type of petrol? See Chap. 7b for all specifications. Also, is the tank cap well tightened? Is there any leak on the supply hose?

6) ENGINE FLYWHEEL COVER: Remove all debris from the area surrounding the engine and, more importantly, from the area above the flywheel cover on the side.

7) ROTOR BRAKE CHECK: before starting to work, from the operator position and with the engine on, engage the rotor, disengage it after few moments, check that the rotor stops completely within 7 seconds.

8) INTEGRITY CHECK on frame and protections: inspect all the frame main hoses, soldered attachments, floor, rotor casing, shock protection and front bumper. Also, check all protection metal covers. Before each use, perform an inspection round on the machine. Report immediately the presence of cracks and **DO NOT USE THE MACHINE**. Check the integrity of all protective skirts (or chains) placed on the rotor casing front and back.

9) PICTOGRAMS CHECK: replace the labels mentioned in Chap. 2a if they are faded, missing or illegible. Ask for replacement copies to your usual retailer and attach them again in their position.

10) HYDROSTATIC FAN AND REAR AREA INSPECTION: check that the entire surface of the rear hydrostatic transmission (as shown in figure) is free from dust or debris. Check that the fan is intact and free to rotate,

so to cool down the transmission below it. **In dusty environments, repeat the debris blowing/cleaning operations several times a day.**

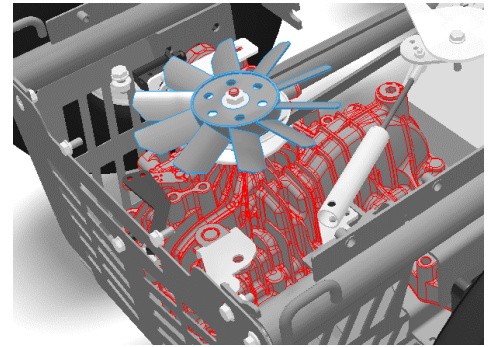

11) CHECK THE LEVEL OF THE HYDROSTATIC OIL: inside the external tank, as described in Chap. 7b.

12) BATTERY: In case of difficult start-up, check that the battery has a voltage of at least 12 V.

7d – CHECKS AND MAINTENANCE OPERATIONS TO BE CARRIED OUT AT REGULAR INTERVALS

While the checks described in the previous paragraph must be carried out by the operator, the following maintenance operations, scheduled at regular intervals, must be performed by a **Meccanica Benassi** authorised workshop. According to the type of use, establish the regularity of service checks together with your usual retailer.

Moreover, please remember that the hour meter of this machine indicates the actual machine running hours and cannot be reset, nor it sends warning messages or deadline reminders. Report the interventions carried out on the **Service Sheet of CHAP. 11**.

Every 50

- Engine oil full replacement => see *Briggs & Stratton* manual.
- Complete replacement of all blades and their fixing bolts.
- Engine oil filter replacement => see *Briggs & Stratton* manual.
- Grease the rotor support bearings: see explanation in the following paragraphs.
- Belt check and adjustment, contact **Meccanica Benassi** for further details.
- Rotor brake check and adjustment, if its stop time became higher than 7 seconds from the moment the PTO lever is released.
- Check, greasing, possible adjustment of pedal control elements, steering wheel tie rods, wired control elements.
- Check of the oil level in the bevel gearbox, see explanation in the following paragraphs.
- Check and possible tightening of all the machine bolts.

Every 100

- TOTAL replacement of the hydrostatic oil + cleaning of the rear transmission's oil filter. => this is a relatively complex operation, contact **Meccanica Benassi** for support.

Note: if the usual noise level of the transmission increases consider the possibility of a total oil replacement even before the 100-hour mark.

Every 150

- Replace the rotor support bearings.

Every 250

- Replace the air filter => see *Briggs & Stratton* manual.

Every 500

- Total replacement of the bevel gearbox oil, see explanation in the following paragraphs.

Once a year

- Replace the spark plugs => see *Briggs & Stratton* manual.

When needed

- Battery replacement:



▶ During maintenance, keep metal objects away from the poles.

▶ Use original batteries only. They are sealed, dry-charged and designed for use on slopes, as they have no acid leaks.

- ▶ Follow the instructions described in the battery manufacturer's manual supplied with this machine manual.

When the battery is disconnected (in order to install another one of the same type):

- Disconnect the negative **black** pole (-)
- Disconnect the positive **red** pole (+)
- Remove the flat battery and install the new one
- Connect the positive **red** pole (+)
- Connect the negative **black** pole (-)

Follow this operation order also when the standard battery is removed to charge it during winter storage. To remove the battery (after disconnecting the poles as indicated), simply disassemble the sheet metal retainer that holds it in place.

PLEASE NOTE: The manufacturer WILL NOT BE RESPONSIBLE for any damage caused by a short circuit due to a wrong pole connection; the same applies to faults caused using non-original batteries!

To be sure that the machine promptly starts at any moment, it is also advisable to periodically check the electrical wiring conditions, as well its connections and terminals. Clean the oxidised contacts and check that covers and sheaths are in good conditions. To protect the electrical components, it is essential to keep the machine away from running water, rain, and humidity.

Moreover, washing the machine with a high-pressure water jet cleaner is STRONGLY DISCOURAGED.

- Tyre or full wheel replacement:



In both cases it is **ESSENTIAL** to replace them with others of the same size and type: the transmission is designed to work exclusively with the wheel sizes established by the manufacturer. **OTHERWISE, THE HYDROSTATIC AXLE WILL SUFFER SERIOUS INTERNAL DAMAGE!**

- Greasing: when needed, the main points to be greased are: front wheel axles, rear wheel axles, steering wheel rack, pedal support axle, rotor support bearings (see next paragraph).

ROTOR SUPPORT BEARINGS GREASING:

Greasing must be performed using the nipples shown below, more specifically:

- on the casing right side, there is an external hose that reaches the bearing, which otherwise would be inaccessible;
- on the casing left side, the grease nipple is located directly on the bearing.



BEVEL GEARBOX: oil level check and possible replacement

The gearbox in the figure on the side is located on the machine right side (from the operator's point of view). It comes pre-loaded in the factory with the right amount of oil. However, as previously said, it is advisable to carry out:

- **EVERY 50 HOURS:** Level check. During belt check operations, which are scheduled at the same intervals, also inspect the gearbox, checking that the level is at the centre of the indicator (see Fig. on the side).
- **EVERY 500 HOURS:** Total replacement. Drain the old oil from the discharge hole and insert the new one (type: **CLP 220** or **80W-90**) from the filling hole (after disassembling the vent pipette, not shown in the figure).

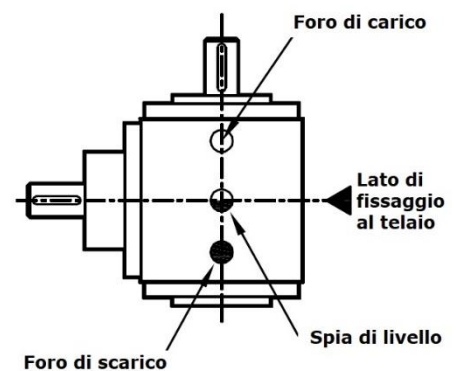

7e - TROUBLESHOOTING

This general guide cannot entirely replace the expertise of an Authorised Workshop, which perfectly knows the product. If the following suggestions are not useful enough to fix a specific issue, it is recommended to contact a service centre.

In case of shock, drift, tip-over or generic damage, even if the machine seems to be intact, it must be inspected as soon as possible by an authorised workshop. It is necessary to check whether the functional and structural parts (frame, engine, hydrostatic axles) are damaged and that there are no liquid spills.
NOTE: even if at first sight no damage is found, the in-depth inspection must be carried out anyway: some faults can be overlooked by an unexperienced user!

■) The STARTER does not turn

- > Start-up electrical consent absent => see CHAP. 6b.
- > Fuses to be replaced => see CHAP. 6b.

-) Battery does not deliver enough voltage/is flat/is faulty => check that the cables are properly connected to the clamps/charge/replace with a new one.

■) The STARTER turns, but the engine does not start

-) Empty petrol tank => Refill.
-) Engine flooded due to continuous use uphill and oil ended up in the combustion chamber or supply circuit => contact a *Briggs & Stratton* authorised workshop.
-) Spark plug caps removed => put them back in position.
-) Air filter clogged/to be replaced => Clean as described in Chap. 7c/replace with a new one.
-) The petrol tank cap vent does not work => Open and then close, check if the engine starts. Get a new cap or bleed the vent valve of the cap.
-) Dirty spark plugs or wrong distance between electrodes => See the engine manual.
-) Dirty petrol and clogged supply hose => Empty the tank, clean the hose, fill with fresh petrol compliant with the specifications contained in CHAP. 7b.
-) Clogged petrol filter => clean as described in the engine manual.

■) ENGINE at the right temperature but still working irregularly

-) Air filter clogged/to be replaced => Clean as described in CHAP. 7c/replace with a new one.
-) Dirty spark plugs or wrong distance between electrodes => See the engine manual.
-) Dirty petrol and partially clogged supply hose => Empty the tank, clean the hose, fill with fresh petrol compliant with the specifications contained in CHAP. 7b.
-) Partially clogged petrol filter => clean as described in the engine manual.

■) The ENGINE starts and works properly, but the machine does not move

-) Rear transmission by-pass lever on OFF => move it immediately to ON, possible damage to the transmission!
-) Parking brake still engaged => Unlock it immediately, possible damage to the transmission!
-) Hydrostatic transmission overheated by intense, prolonged use, on slopes and at high ambient temperatures => allow the machine to cool down completely before resuming work.

■) The ENGINE turns accidentally off during work

-) The operator is not correctly seated: human presence switch not pressed => the operator must change the way is seated/decrease the speed if the issue is caused by holes on the ground.
-) Too much effort: forward speed is too high/cutting height not proportional to the terrain/throttle not at its maximum RPMs => decrease the forward speed/raise the cutting height/bring the throttle to the maximum.
-) Petrol has run out => Fill the tank.
-) Petrol picking issues due to the use on slopes and tank almost empty => fill up.
-) Petrol picking issues on flat surfaces and with the tank full => check the petrol hose coming out the tank and/or the engine petrol filter, so to check for the presence of impurities to be removed.
-) Extreme overheating => Let engine and machine cool down and avoid working in such conditions. Wait for better conditions or take more frequent breaks.
-) Engine electrical issue => contact *Briggs & Stratton*.

■) The ROTOR does not engage

-) Broken PTO engagement cable => replace it.
-) Stretched rotor belt, now it slips => adjust or replace it.
-) Belt from engine to gearbox too loose or slipping, pulley issue => adjust or replace it.

■) **The machine VIBRATES more than expected**

-) Missing, broken, bent blades => see CHAP. 7c 4).
-) Loosened fixing bolts => Tighten immediately and consider a total replacement of the fixing nuts, if they have lost their locking ability (M10 self-locking nuts, cone-lock type).
-) Blades and bolts are in good conditions, rotor bent due to the hits received => total rotor replacement carried out by an authorised workshop.
-) Loosened engine plate => tighten the 4 bolts fixing the engine to the plate and the 4 bolts fixing the plate to the rest of the frame.

■) **The machine makes more NOISE than expected**

-) If the noise does not come from the rotor but from the machine rear part => lubricate with WD 40 the hoses containing the contrast springs of the belt tensioners under the engine.
-) If the noise comes from the hydrostatic transmission => wait until the machine has cooled down and check if the noise goes away; if not, inspect and then completely replace the oil at an authorised workshop.
-) Exhaust issues => check the tightening of the band holding the muffler on the manifold.

■) **The engine produces anomalous SMOKE (it burns oil)**

-) The engine burns oil because the machine is used uphill too much => reduce the exposure of the engine heads downstream, and alternate uphill cutting operations with downhill ones and "recovery" times on flat surfaces more often.
-) The engine oil level is too high => proceed as described in CHAP. 7b, do not fill over the indicated MAX limit.

■) **The ENGINE gets too hot**

-) Presence of debris all around the engine and especially in the upper part, close to the flywheel cover => Free all engine surfaces from debris build-ups, especially the upper part.
-) Oil quantity in the block is too low => fill up immediately as described in CHAP. 7b and in the engine manufacturer manual.

■) **CUTTING RESULTS are uneven**

-) Blades partially broken, worn or missing => Proceed as described in CHAP. 7c 4)
-) The mowing deck is clogged => It is necessary to start working with a clean mowing deck internal volume, as described in CHAP. 7c 3)! Wash using the supplied sleeves. **The cutting quality strongly depends on the free volume around the rotor!**
-) The engine (and, therefore, the rotor) is not turning at its maximum RPMs => Bring the throttle to the maximum during cutting operations, so to have an ideal impact speed.
-) The forward speed and/or cutting height are not proportional to the type of terrain and density of the vegetation to be cut => decrease the speed and raise mowing deck until an ideal cut is achieved. If necessary, pass on the vegetation cut once more.
-) If the vegetation cut is asymmetrical, it is likely that the rotor casing received some hits which have bent the lifting rods or the hinge on which it rotates, tilting it on one side => have the machine checked by an authorised workshop.
-) If the vegetation cut is asymmetrical and the mowing deck did not receive hits => check the tyres pressure, looking for possible differences between left and right wheels.
-) If on an exclusively grassy terrain the vegetation cut is too coarse => INCREASE the travel speed lowering the rotor height, so to clog the casing more and increase the grinding before the vegetation is discharged on the ground. On the other hand, IF THE TERRAIN HAS BRANCHES OR SHRUBS, these precautions are counterproductive.

■) **Rotor CASING clogged**

-) The terrain is too wet => Clean the casing internal part more frequently, raise the cutting height, consider if more than one attempt is needed, or work when the weather is drier.
-) Worn blades => Replace them, as a poor grinding due to a worn-out cutting element leads to further build-ups.

■) **THE MACHINE DOES NOT BRAKE even if the tyres have a good grip**

-) The pedal brake does not work as it should => Immediately contact an authorised workshop.

■) **THE ENGINE DOES NOT TURN OFF moving the key to OFF**

-) Faulty electrical system => Disengage the rotor, wait it to stop, bring the throttle to the minimum, get up from the seat and wait until the machine turns off before getting off. Before any further use, have it checked by a service centre.

■) **TYRES are subject to frequent punctures**

-) If this is due to the type of terrain and vegetation to be cut (and not to faults on rims or valves) => consider the use of an anti-puncture gel.

■) **The BATTERY does not charge**

-) The wiring charging circuit does not work properly => check the 20 A fuse, replace it and try again
-) The engine alternator does not work properly => *Briggs & Stratton* service centre.
-) Faulty battery => replace it.

■) **THE TRAVEL DIRECTION PEDAL does not return in neutral position when the foot is raised**

-) The cable connected to the pedal does not move properly and struggles coming back => Lubricate it.
-) The pedal support pin does not move properly => Lubricate it.

8 – STORAGE AND DISPOSAL

– **Short-term storage** (< 1 month): park the machine in a closed, dry area after having allowed it to cool down completely. Cover the machine with a sheet. Periodically check that the battery charge does not go under 12 V.

– **Long-term storage** (> 1 month): in addition to the precautions mentioned for short-term storage, it is advisable to empty the petrol tank, so to prevent the creation of build-ups; lubricate and grease the parts mentioned in CHAP. 7d. Fuel must be kept in fresh, dry places, away from light and ignition sources, in approved containers suitable for this purpose.

During long stops, keep the battery under charge! The manufacturer will not accept any warranty claim caused by batteries found to be flat when works are resumed after winter storage.

– **Machine disposal at the end of its life**: the tractor is composed of different parts, whose disposal might follow different approaches according to the country. It is essential to take care of a correct disposal, especially in the case of lubricating oil, petrol, battery, and tyres, which are considered special waste in most of the countries where this machine might be used. The rest of the machine is mostly composed of iron plates. Contact the organisations entrusted with this task and NEVER dispose of the waste in the environment.

9a– TECHNICAL DATA

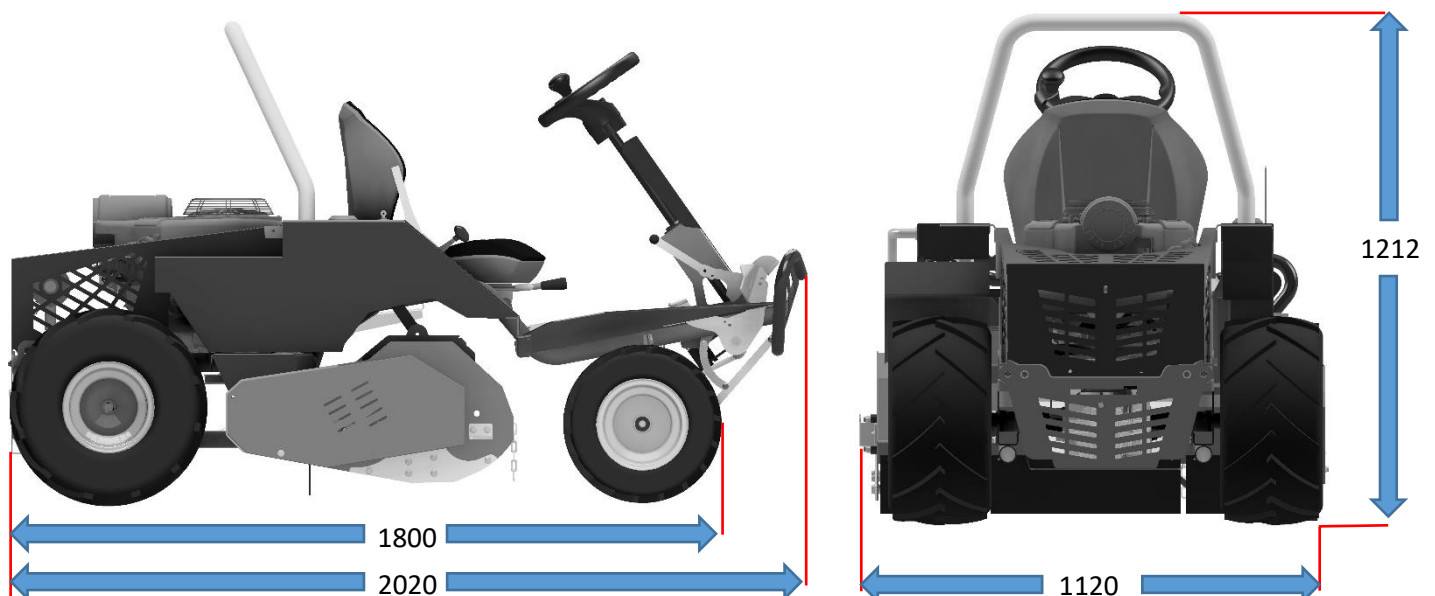

FOX - 95-2WD	
Total length	2020 mm
Total width	1120 mm
Total height	1212 mm
Pitch	1350 mm
Seat height	662 mm
Weight in working order	366 kg
Wheel drive	Rear
Transmission from engine to axle	Belt
Hydrostatic transmission	Tuff-Torq K-664E
Cutting element type	Flail rotor
Cutting levels	4 fixed 6 floating
Cutting height range	30 - 92 mm
Actual cutting width	950 mm
No. of blades	52 (= 26 Y-shaped pairs)
Rotor speed and direction	3400 RPM / backwards
Transmission from engine to rotor	Belt
PTO start	Mechanical, with lever
Front track (external)	970 mm
Rear track (external)	1,025 mm
Front wheels	16x6.50-8 Tractor
Rear wheels	20x10-8 Tractor
Tyre pressure	1,5 bar
Petrol tank capacity	13,2 L
Oil tank capacity	0,7 L
Cutting capacity at 8 km/h	7600 m ² /h
Max. transfer speed	9 km/h (F) - 7 km/h (R)
Fuses	15 A ; 20 A
Battery	12 V-28 Ah
V-Twin engine features	Briggs & Stratton 7220 Commercial (40T8 series)
Displacement	656 cc
Fuel	Petrol
Air filter	Cyclonic
Engine shaft	Ø25.4 x 80 mm
Max. usage RPM	3400 RPM
Net power @ 3,400 rpm	13.51 kW (18.4 CV)
Start-up	Electrical
Air management for start-up	Manual choke
NOISE AND VIBRATIONS	
Acoustic power (EN ISO 4254-1)	L _{wa} = 105.1 dBA ± 3 dBA
Acoustic pressure (EN ISO 4254-1)	L _{pa} = 96.1 dBA ± 3 dBA
Seat vibrations (EN 12096)	a = 0.52 m/s ² ± 0.10 m/s ²
Steering wheel vibrations (EN 12096) <i>maximum value</i>	a = 3.74 m/s ² ± 0.13 m/s ²

9b – ELECTRICAL SYSTEM DIAGRAM

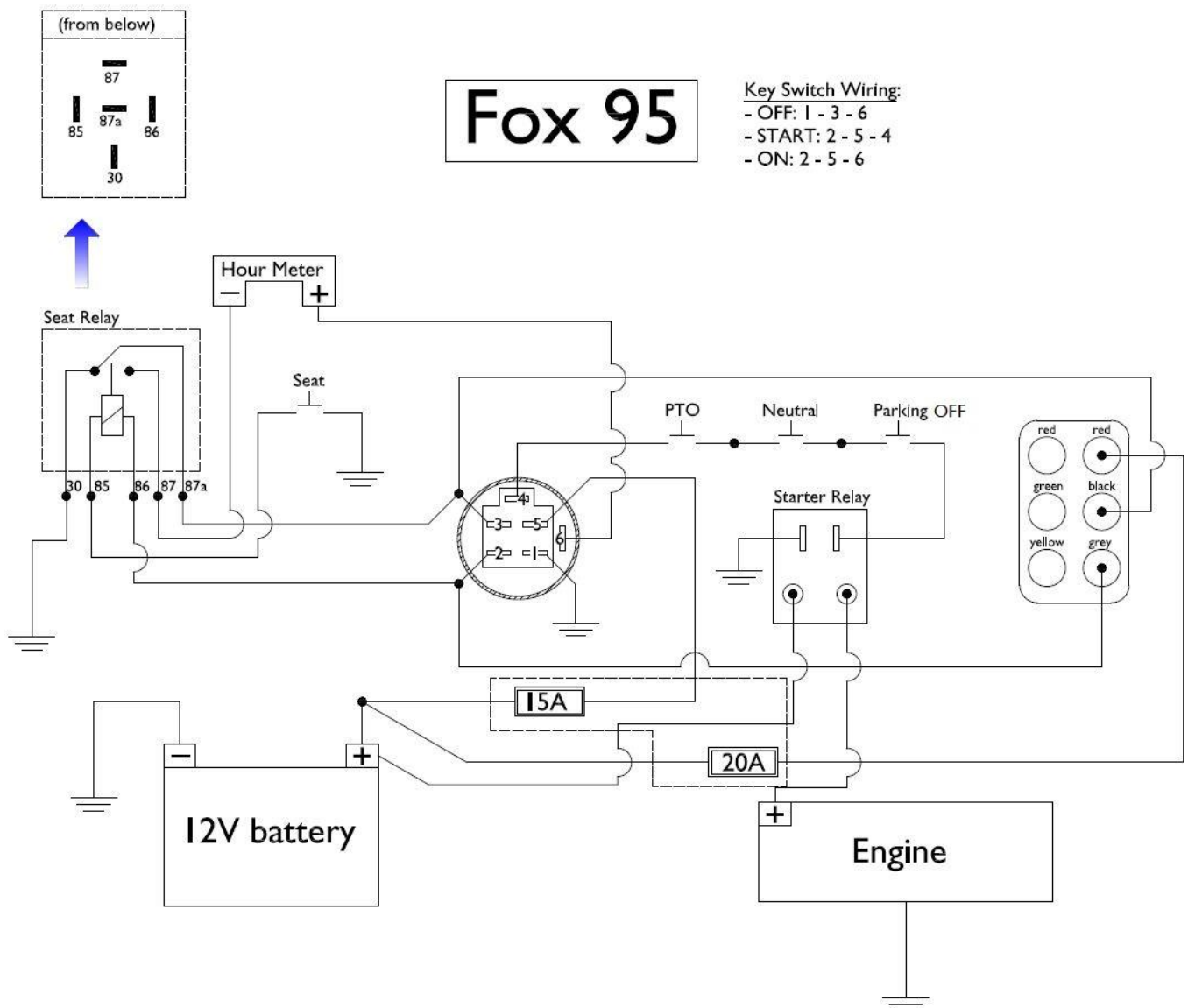

10 – WARRANTY

Meccanica Benassi S.r.l (as well as its business partners, such as the engine and hydrostatic transmission manufacturers) has the right to refuse any responsibility and reject refund requests deriving from damage caused to the machine or to objects, people, animals and property in cases of:

- Warranty claims deriving from damage to the machine occurred after the first 24 months from the date of purchase by the end customer
- Faults not promptly reported and repaired
- Use of non-original spare parts
- Damage caused by poor maintenance, especially warranty claims due to flat batteries after winter storage
- Damage caused by incorrect, unforeseen use (see *Chap. 1c* and *1d*), accidents or tip-over
- Repairs carried out by a workshop NOT authorised by the manufacturer
- Lack of documentary evidence to support the claim (serial number, receipt or purchase invoice, photos or videos of the faults, communication of total hours with photos, scanned copy or picture of the Service Sheet of *Chap. 11*)



MECCANICA BENASSI S.r.l.

SHARE CAPITAL € 619,200 FULLY PAID-UP

REGISTERED OFFICE AND FACTORY: VIA STATALE 325, DOSSO – 44047 TERRE DEL RENO (FE) ITALY

www.benassi.it/en e-mail: info@benassi.it

TEL. +39 0532 848193

FAX +39 051 0822449

R.E.A. (Economic
Administrative Index) FE 97187

EXPORT FE 001080

FERRARA BUSINESS REGISTER

TAX CODE 00341260388

VAT 00341260388

ISO - IT00341260388

DECLARATION OF CONFORMITY

Annex IIA - 2006/42/EC

The company **Meccanica Benassi Srl** with registered office in Dosso, via Statale 325, 44047 Terre di Reno (FE) - Italy, as manufacturer and holder of the technical documentation, declares that the machine:

Type: ride-on flail mower with operator on board

Model: **FOX 95-2WD**

Serial Number: C300001 to C399999

Power @ 3400 rpm: 13.51 kW

Mass (dry): 355 kg

is compliant with the following directives/regulations:

2006/42/EC (EN ISO 12100; EN ISO 4254-1:2018)

2014/30/EU

2011/65/EU and subsequent amendments

Dosso, October 2020

Silvano Benassi
Sole Director